

WD切断切槽刀杆
WD Part-off and grooving

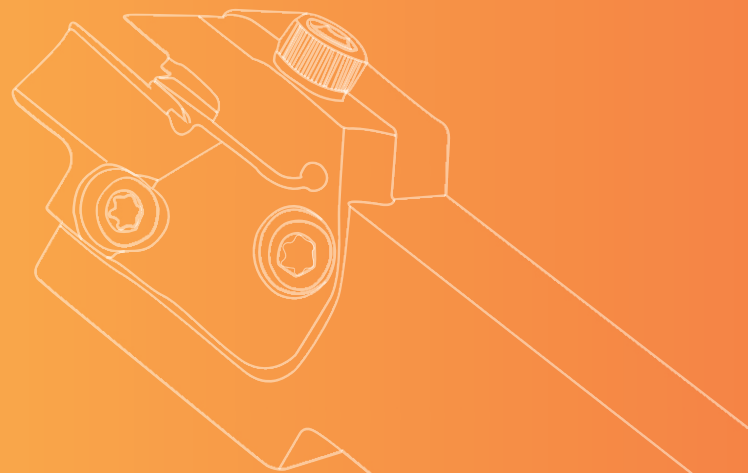

KOVES[®]
Part-off and grooving system

Moular part-off and grooving tools

Blades >> For external
>> For face grooving

Par-off block

We have a passion for quality



KOVES

www.kovestool.cn

WD模块式切槽刀

WD Moular part-off and grooving tools

Holder

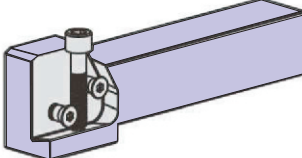
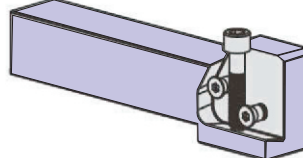
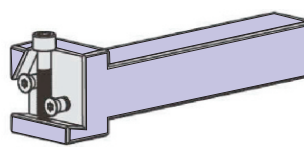
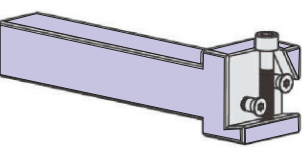
Horizontal Type		Vertical Type	
HDR	HDL	HER	HEL
			

Cartridge

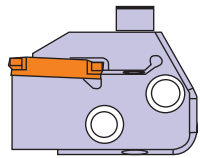
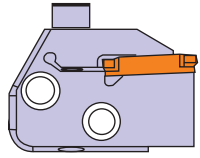
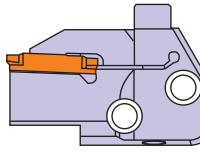
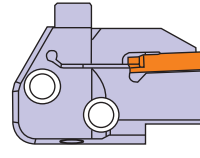
External Process		Facing Process	
HWDR	HWDL	HFDR	HFDL
			

因为采用独立刀座设计,与现存一体式刀具相比: 适用性和经济性得到提高!

可以替换的刀座: 可根据工件类型改变安装方式减少刀具切削成本30%左右

强大稳固的夹紧力: 刀片和刀座刀座安装可同时进行安装和更换很方便

稳固的安装系统: 安装简便,加紧力强.

Because of using independent tool holder design,

Compared with existing integrated tool:

The Applicability and economy are improved!

Replace able cutter holder:

You can change the type of installation according to the workpiece,

the cutting tool costs can be reduced by about 30%

Strong and Stable clamping force:

the carbide insert and cutter holder can be installed at the same time,

installation and replacement are very convenient

WD刀片槽型

Chipbreakers >>

F



非常流畅的切削形状与低切削力
用于低中强度范围内的所有材料
产生积屑瘤小
适用于薄壁的工件

Very soft cutting geometry
For low to medium strength materials
with low built-up edge tendency

T



非常好的切削槽和收缩形状的断屑槽
用于钢件和不锈钢加工
普遍适用各类加工环境
甚至用于薄壁零件

Very good swarf control and formation
Universal geometry for steel and stainless steel
machining ,also for thin-walled components

M



采用负角及倒角的几何设计
用于再中高强度内的所有材料
普遍用于钢件, 不锈钢和铸铁
在稳定的条件下首选槽型

Geometry with small negative chamfer for
medium to high strength materials
suitable for all steels(stainless and cast)
first choice where cutting conditions are solid

WD模块式切槽刀

WD Moular part-off and grooving tools

外径切槽刀板HWDR/L..
Blades >> For external

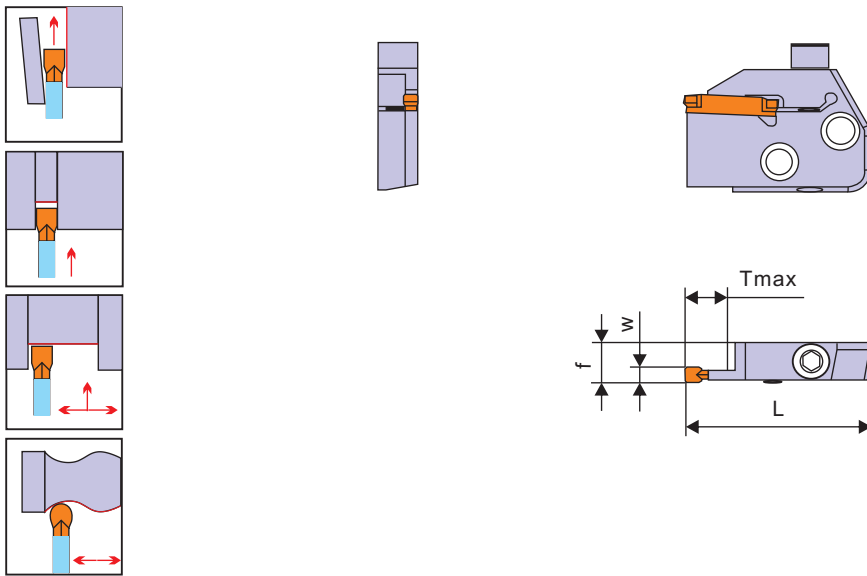

型号 Type	刀片 Inserts	W	Tmax	L	f	适合刀座 Apply for	重量 (kg)	单价 (RMB)
HWDR200-10	WD22N2.00..	2	10	46	10.3	HDR/HEL	0.10	252.00
HWDL200-10	WD22N2.00..	2	10	46	10.3	HDL/HER	0.10	252.00
HWDR200-22	WD22N2.00..	2	22	58	10.3	HDR/HEL	0.10	252.00
HWDL200-22	WD22N2.00..	2	22	58	10.3	HDL/HER	0.10	252.00
HWDR250-10	WD22N2.50..	2.5	10	46	10.3	HDR/HEL	0.10	252.00
HWDL250-10	WD22N2.50..	2.5	10	46	10.3	HDL/HER	0.10	252.00
HWDR250-22	WD22N2.50..	2.5	22	58	10.3	HDR/HEL	0.10	252.00
HWDL250-22	WD22N2.50..	2.5	22	58	10.3	HDL/HER	0.10	252.00
HWDR300-10	WD22N3.00..	3	10	46	10.3	HDR/HEL	0.10	252.00
HWDL300-10	WD22N3.00..	3	10	46	10.3	HDL/HER	0.10	252.00
HWDR300-22	WD22N3.00..	3	22	58	10.3	HDR/HEL	0.10	252.00
HWDL300-22	WD22N3.00..	3	22	58	10.3	HDL/HER	0.10	252.00
HWDR400-13	WD25N4.00..	4	13	49	10.6	HDR/HEL	0.15	252.00
HWDL400-13	WD25N4.00..	4	13	49	10.6	HDL/HER	0.15	252.00
HWDR400-25	WD25N4.00..	4	25	61	10.6	HDR/HEL	0.15	252.00
HWDL400-25	WD25N4.00..	4	25	61	10.6	HDL/HER	0.15	252.00
HWDR500-13	WD25N5.00..	5	13	49	10.6	HDR/HEL	0.15	252.00
HWDL500-13	WD25N5.00..	5	13	49	10.6	HDL/HER	0.15	252.00
HWDR500-25	WD25N5.00..	5	25	61	10.6	HDR/HEL	0.15	252.00
HWDL500-25	WD25N5.00..	5	25	61	10.6	HDL/HER	0.15	252.00

WD模块式切槽刀

WD Moular part-off and grooving tools

端面切槽刀板 HFDR/L300..

Blades >> For face grooving

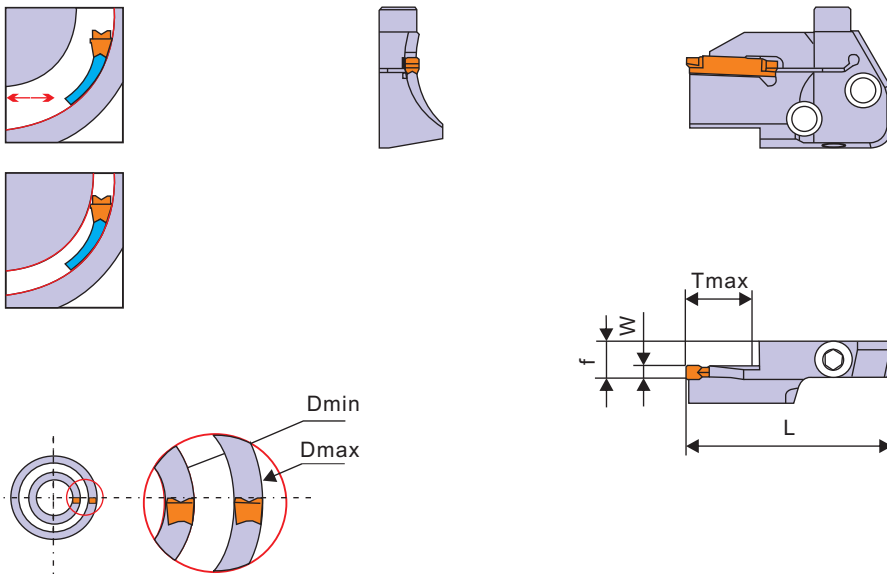

型号 Type	刀片 Inserts	W	Tmax	L	f	Dmin-Dmax	适合刀座 Apply for	重量 (kg)	单价 (RMB)
HFDR300034-12	WD22N3.00..	3	12	48	10.3	34-44	HDR/HEL	0.10	460.00
HFDL300034-12	WD22N3.00..	3	12	48	10.3	34-44	HDL/HER	0.10	460.00
HFDR300038-12	WD22N3.00..	3	12	48	10.3	38-48	HDR/HEL	0.10	460.00
HFDL300038-12	WD22N3.00..	3	12	48	10.3	38-48	HDL/HER	0.10	460.00
HFDR300042-12	WD22N3.00..	3	12	48	10.3	42-60	HDR/HEL	0.10	460.00
HFDL300042-12	WD22N3.00..	3	12	48	10.3	42-60	HDL/HER	0.10	460.00
HFDR300042-19	WD22N3.00..	3	19	55	10.3	40-60	HDR/HEL	0.10	460.00
HFDL300042-19	WD22N3.00..	3	19	55	10.3	40-60	HDL/HER	0.10	460.00
HFDR300054-12	WD22N3.00..	3	12	48	10.3	54-75	HDR/HEL	0.10	460.00
HFDL300054-12	WD22N3.00..	3	12	48	10.3	54-75	HDL/HER	0.10	460.00
HFDR300054-19	WD22N3.00..	3	19	55	10.3	54-75	HDR/HEL	0.10	460.00
HFDL300054-19	WD22N3.00..	3	19	55	10.3	54-75	HDL/HER	0.10	460.00
HFDR300067-12	WD22N3.00..	3	12	48	10.3	67-100	HDR/HEL	0.10	460.00
HFDL300067-12	WD22N3.00..	3	12	48	10.3	67-100	HDL/HER	0.10	460.00
HFDR300067-22	WD22N3.00..	3	22	58	10.3	67-100	HDR/HEL	0.10	460.00
HFDL300067-22	WD22N3.00..	3	22	58	10.3	67-100	HDL/HER	0.10	460.00
HFDR300090-12	WD22N3.00..	3	12	48	10.3	90-160	HDR/HEL	0.10	460.00
HFDL300090-12	WD22N3.00..	3	12	48	10.3	90-160	HDL/HER	0.10	460.00
HFDR300090-22	WD22N3.00..	3	22	58	10.3	90-160	HDR/HEL	0.10	460.00
HFDL300090-22	WD22N3.00..	3	22	58	10.3	90-160	HDL/HER	0.10	460.00
HFDR300130-12	WD22N3.00..	3	12	48	10.3	130-300	HDR/HEL	0.10	460.00
HFDL300130-12	WD22N3.00..	3	12	48	10.3	130-300	HDL/HER	0.10	460.00
HFDR300130-22	WD22N3.00..	3	22	58	10.3	130-300	HDR/HEL	0.10	460.00
HFDL300130-22	WD22N3.00..	3	22	58	10.3	130-300	HDL/HER	0.10	460.00

WD模块式切槽刀

WD Moular part-off and grooving tools

端面切槽刀板 HFDR/L400..

Blades >> For face grooving

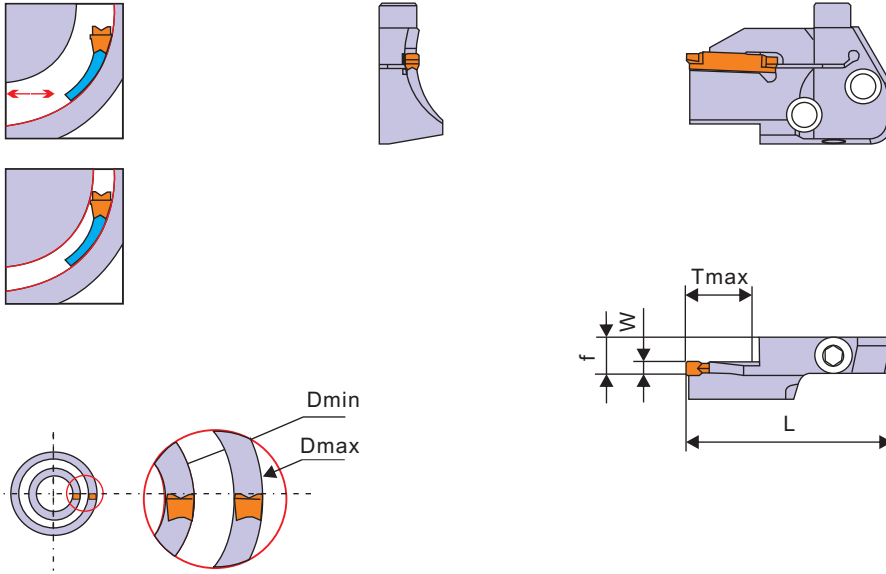

型号 Type	刀片 Inserts	W	Tmax	L	f	Dmin-Dmax	适合刀座 Apply for	重量 (kg)	单价 (RMB)
HFDR400040-13	WD25N4.00..	4	13	49	10.6	40-60	HDR/HEL	0.15	460.00
HFDL400040-13	WD25N4.00..	4	13	49	10.6	40-60	HDL/HER	0.15	460.00
HFDR400040-25	WD25N4.00..	4	25	61	10.6	40-60	HDR/HEL	0.15	460.00
HFDL400040-25	WD25N4.00..	4	25	61	10.6	40-60	HDL/HER	0.15	460.00
HFDR400052-13	WD25N4.00..	4	13	49	10.6	52-72	HDR/HEL	0.15	460.00
HFDL400052-13	WD25N4.00..	4	13	49	10.6	52-72	HDL/HER	0.15	460.00
HFDR400052-25	WD25N4.00..	4	25	61	10.6	52-72	HDR/HEL	0.15	460.00
HFDL400052-25	WD25N4.00..	4	25	61	10.6	52-72	HDL/HER	0.15	460.00
HFDR400064-13	WD25N4.00..	4	13	49	10.6	64-100	HDR/HEL	0.15	460.00
HFDL400064-13	WD25N4.00..	4	13	49	10.6	64-100	HDL/HER	0.15	460.00
HFDR400064-25	WD25N4.00..	4	25	61	10.6	64-100	HDR/HEL	0.15	460.00
HFDL400064-25	WD25N4.00..	4	25	61	10.6	64-100	HDL/HER	0.15	460.00
HFDR400092-13	WD25N4.00..	4	13	49	10.6	92-140	HDR/HEL	0.15	460.00
HFDL400092-13	WD25N4.00..	4	13	49	10.6	92-140	HDL/HER	0.15	460.00
HFDR400092-25	WD25N4.00..	4	25	61	10.6	92-140	HDR/HEL	0.15	460.00
HFDL400092-25	WD25N4.00..	4	25	61	10.6	92-140	HDL/HER	0.15	460.00
HFDR400132-13	WD25N4.00..	4	13	49	10.6	132-230	HDR/HEL	0.15	460.00
HFDL400132-13	WD25N4.00..	4	13	49	10.6	132-230	HDL/HER	0.15	460.00
HFDR400132-25	WD25N4.00..	4	25	61	10.6	132-230	HDR/HEL	0.15	460.00
HFDL400132-25	WD25N4.00..	4	25	61	10.6	132-230	HDL/HER	0.15	460.00
HFDR400220-13	WD25N4.00..	4	13	49	10.6	220-500	HDR/HEL	0.15	460.00
HFDL400220-13	WD25N4.00..	4	13	49	10.6	220-500	HDL/HER	0.15	460.00
HFDR400220-25	WD25N4.00..	4	25	61	10.6	220-500	HDR/HEL	0.15	460.00
HFDL400220-25	WD25N4.00..	4	25	61	10.6	220-500	HDL/HER	0.15	460.00
HFDR400300-13	WD25N4.00..	4	13	49	10.6	300-	HDR/HEL	0.15	460.00
HFDL400300-13	WD25N4.00..	4	13	49	10.6	300-	HDL/HER	0.15	460.00
HFDR400300-25	WD25N4.00..	4	25	61	10.6	300-	HDR/HEL	0.15	460.00
HFDL400300-25	WD25N4.00..	4	25	61	10.6	300-	HDL/HER	0.15	460.00

WD 模块式切槽刀

WD Moular part-off and grooving tools

端面切槽刀板 HFDR/L500..

Blades >> For face grooving

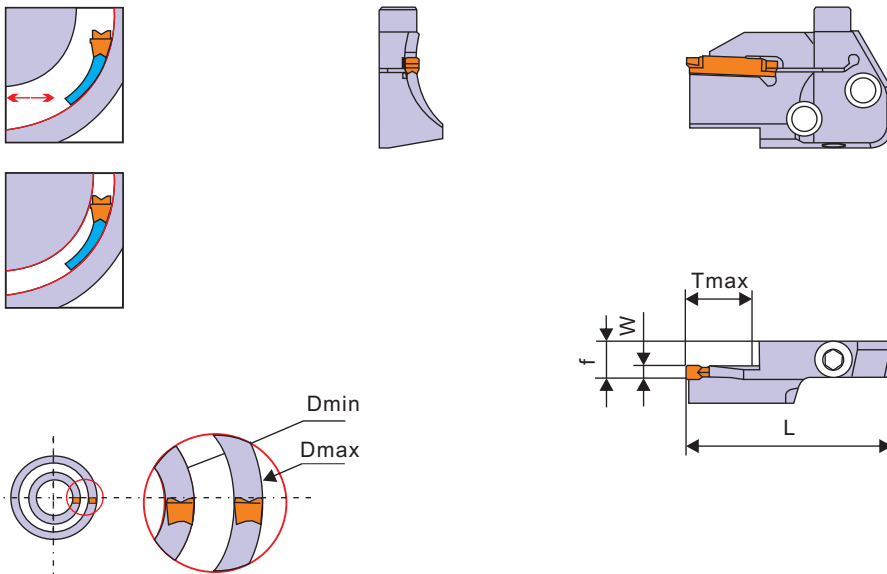

型号 Type	刀片 Inserts	W	Tmax	L	f	Dmin-Dmax	适合刀座 Apply for	重量 (kg)	单价 (RMB)
HFDR500040-13	WD25N5.00..	5	13	49	10.6	40-70	HDR/HEL	0.18	460.00
HFDL500040-13	WD25N5.00..	5	13	49	10.6	40-70	HDL/HER	0.18	460.00
HFDR500040-25	WD25N5.00..	5	25	61	10.6	40-70	HDR/HEL	0.18	460.00
HFDL500040-25	WD25N5.00..	5	25	61	10.6	40-70	HDL/HER	0.18	460.00
HFDR500060-13	WD25N5.00..	5	13	49	10.6	60-95	HDR/HEL	0.18	460.00
HFDL500060-13	WD25N5.00..	5	13	49	10.6	60-95	HDL/HER	0.18	460.00
HFDR500060-25	WD25N5.00..	5	25	61	10.6	60-95	HDR/HEL	0.18	460.00
HFDL500060-25	WD25N5.00..	5	25	61	10.6	60-95	HDL/HER	0.18	460.00
HFDR500085-13	WD25N5.00..	5	13	49	10.6	85-130	HDR/HEL	0.18	460.00
HFDL500085-13	WD25N5.00..	5	13	49	10.6	85-130	HDL/HER	0.18	460.00
HFDR500085-25	WD25N5.00..	5	25	61	10.6	85-130	HDR/HEL	0.18	460.00
HFDL500085-25	WD25N5.00..	5	25	61	10.6	85-130	HDL/HER	0.18	460.00
HFDR500120-13	WD25N5.00..	5	13	49	10.6	120-180	HDR/HEL	0.18	460.00
HFDL500120-13	WD25N5.00..	5	13	49	10.6	120-180	HDL/HER	0.18	460.00
HFDR500120-25	WD25N5.00..	5	25	61	10.6	120-180	HDR/HEL	0.18	460.00
HFDL500120-25	WD25N5.00..	5	25	61	10.6	120-180	HDL/HER	0.18	460.00
HFDR500175-13	WD25N5.00..	5	13	49	10.6	175-500	HDR/HEL	0.18	460.00
HFDL500175-13	WD25N5.00..	5	13	49	10.6	175-500	HDL/HER	0.18	460.00
HFDR500175-25	WD25N5.00..	5	25	61	10.6	175-500	HDR/HEL	0.18	460.00
HFDL500175-25	WD25N5.00..	5	25	61	10.6	175-500	HDL/HER	0.18	460.00
HFDR500180-13	WD25N5.00..	5	13	49	10.6	180-	HDR/HEL	0.18	460.00
HFDL500180-13	WD25N5.00..	5	13	49	10.6	180-	HDL/HER	0.18	460.00
HFDR500180-25	WD25N5.00..	5	25	61	10.6	180-	HDR/HEL	0.18	460.00
HFDL500180-25	WD25N5.00..	5	25	61	10.6	180-	HDL/HER	0.18	460.00

WD 模块式切槽刀

WD Moular part-off and grooving tools

纵向型刀座HDR/L..

Part-off block

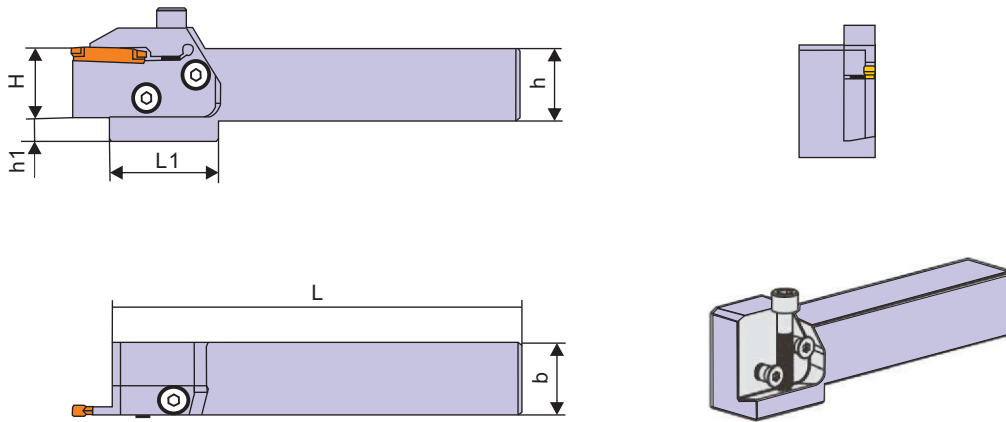

型号 Type	h	b	H	L	L1	h1	适合刀板 Apply for	重量 (kg)	单价 (RMB)
HDR2020K	20	20	20	110	32	12	HWDR/HFDL	0.60	172.00
HDL2020K	20	20	20	110	32	12	HWDL/HFDR	0.60	172.00
HDR2525M	25	25	25	135	32	7	HWDR/HFDL	0.80	182.00
HDL2525M	25	25	25	135	32	7	HWDL/HFDR	0.80	182.00
HDR3225P	32	25	32	155	32	-	HWDR/HFDL	0.90	194.00
HDL3225P	32	25	32	155	32	-	HWDL/HFDR	0.90	194.00
HDR3232P	32	32	32	155	32	-	HWDR/HFDL	1.00	208.00
HDL3232P	32	32	32	155	32	-	HWDL/HFDR	1.00	208.00
HDR4040R	40	40	40	180	32	-	HWDR/HFDL	1.50	306.00
HDL4040R	40	40	40	180	32	-	HWDL/HFDR	1.50	306.00

备件/SPARE PARTS



螺钉
Screw
BX060400



扳手
Wrench
LH050



螺钉
Screw
BS060160



扳手
Wrench
LT25

WD 模块式切槽刀

WD Moular part-off and grooving tools

横向型刀座 HER/L..

Part-off block

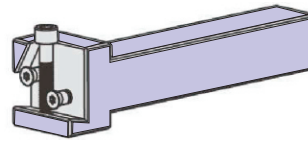
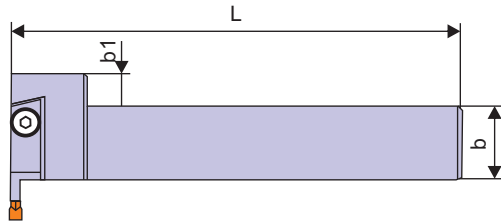
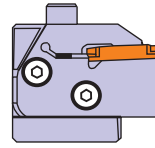
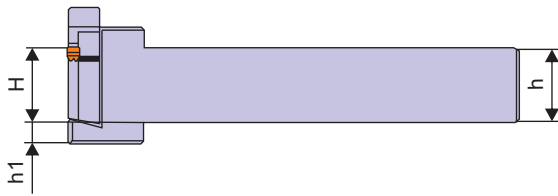

型号 Type	h	b	H	L	L ₁	h ₁	适合刀板 Apply for	重量 (kg)	单价 (RMB)
HER2020K	20	20	20	110	32	12	HWDR/HFDL	0.60	218.00
HEL2020K	20	20	20	110	32	12	HWDL/HFDR	0.60	218.00
HER2525M	25	25	25	135	32	7	HWDR/HFDL	0.80	236.00
HEL2525M	25	25	25	135	32	7	HWDL/HFDR	0.80	236.00
HER3225P	32	25	32	155	32	-	HWDR/HFDL	0.90	256.00
HEL3225P	32	25	32	155	32	-	HWDL/HFDR	0.90	256.00
HER3232P	32	32	32	155	32	-	HWDR/HFDL	1.00	352.00
HEL3232P	32	32	32	155	32	-	HWDL/HFDR	1.00	352.00
HER4040R	40	40	40	180	32	-	HWDR/HFDL	1.50	366.00
HEL4040R	40	40	40	180	32	-	HWDL/HFDR	1.50	366.00

备件/SPARE PARTS



螺钉
Screw
BX060400



扳手
Wrench
LH050



螺钉
Screw
BS060160



扳手
Wrench
LT25

WD 外径切断刀杆

WDTool holder >> for external
TWDR/L..

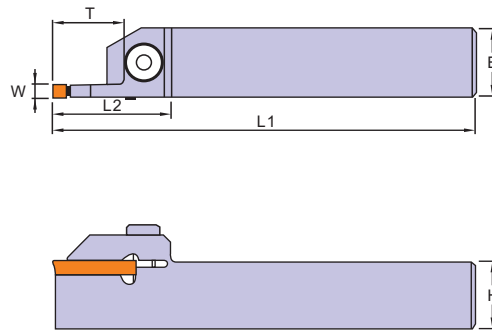
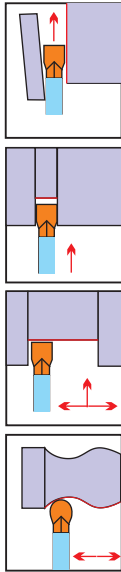

型号 Type	W	H	B	L	T	螺钉 Screw	扳手 Wrench	刀片 Inserts	重量 (kg)	单价 (RMB)
TWDR1212K-2T12	2	12	12	125	12	BS0407	LT15	WD22N2.00..	0.16	280.00
TWDL1212K-2T12	2	12	12	125	12	BS0407	LT15	WD22N2.00..	0.16	280.00
TWDR1616K-2T17	2	16	16	125	17	BX0520	LH040	WD22N2.00..	0.22	280.00
TWDL1616K-2T17	2	16	16	125	17	BX0520	LH040	WD22N2.00..	0.22	280.00
TWDR2020K-2T17	2	20	20	125	17	BX0620	LH050	WD22N2.00..	0.37	280.00
TWDL2020K-2T17	2	20	20	125	17	BX0620	LH050	WD22N2.00..	0.37	280.00
TWDR2525M-2T17	2	25	25	150	17	BX0620	LH050	WD22N2.00..	0.69	308.00
TWDL2525M-2T17	2	25	25	150	17	BX0620	LH050	WD22N2.00..	0.69	308.00
TWDR1616K-3T14	3	16	16	125	14	BX0520	LH040	WD22N3.00..	0.22	280.00
TWDL1616K-3T14	3	16	16	125	14	BX0520	LH040	WD22N3.00..	0.22	280.00
TWDR1616K-3T20	3	16	16	125	20	BX0520	LH040	WD22N3.00..	0.22	280.00
TWDL1616K-3T20	3	16	16	125	20	BX0520	LH040	WD22N3.00..	0.22	280.00
TWDR2020K-3T09	3	20	20	125	09	BX0620	LH050	WD22N3.00..	0.37	280.00
TWDL2020K-3T09	3	20	20	125	09	BX0620	LH050	WD22N3.00..	0.37	280.00
TWDR2020K-3T20	3	20	20	125	20	BX0620	LH050	WD22N3.00..	0.37	280.00
TWDL2020K-3T20	3	20	20	125	20	BX0620	LH050	WD22N3.00..	0.37	280.00
TWDR2525M-3T09	3	25	25	150	09	BX0620	LH050	WD22N3.00..	0.69	308.00
TWDL2525M-3T09	3	25	25	150	09	BX0620	LH050	WD22N3.00..	0.69	308.00
TWDR2525M-3T20	3	25	25	150	20	BX0620	LH050	WD22N3.00..	0.69	308.00
TWDL2525M-3T20	3	25	25	150	20	BX0620	LH050	WD22N3.00..	0.69	308.00
TWDR2020K-4T10	4	20	20	125	10	BX0620	LH050	WD25N4.00..	0.37	308.00
TWDL2020K-4T10	4	20	20	125	10	BX0620	LH050	WD25N4.00..	0.37	280.00
TWDR2020K-4T20	4	20	20	125	20	BX0620	LH050	WD25N4.00..	0.37	280.00
TWDL2020K-4T20	4	20	20	125	20	BX0620	LH050	WD25N4.00..	0.37	280.00
TWDR2525M-4T10	4	25	25	150	10	BX0620	LH050	WD25N4.00..	0.69	308.00
TWDL2525M-4T10	4	25	25	150	10	BX0620	LH050	WD25N4.00..	0.69	308.00
TWDR2525M-4T20	4	25	25	150	20	BX0620	LH050	WD25N4.00..	0.69	308.00
TWDL2525M-4T20	4	25	25	150	20	BX0620	LH050	WD25N4.00..	0.69	308.00
TWDR2525M-5T12	5	25	25	150	12	BX0620	LH050	WD25N5.00..	0.69	308.00
TWDL2525M-5T12	5	25	25	150	12	BX0620	LH050	WD25N5.00..	0.69	308.00
TWDR2525M-5T25	5	25	25	150	25	BX0620	LH050	WD25N5.00..	0.69	308.00
TWDL2525M-5T25	5	25	25	150	25	BX0620	LH050	WD25N5.00..	0.69	308.00

Wd内径切槽刀架

WDTool holder >> for internal
TIWDR/L

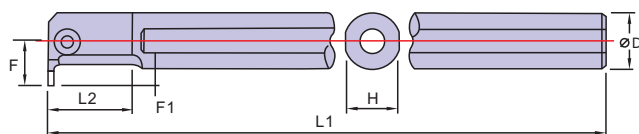
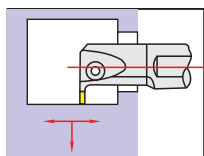

型号 Type	W	D	F	F1	L1	L2	Dmin	螺钉 Screw	扳手 Wrench	刀片 Inserts	重量 (kg)	单价 (RMB)
TIWDR2025-2T06	2	20	15	6	180	40	25	BX0520	LH040	WD22N2.00..	0.46	340.00
TIWDL2025-2T06	2	20	15	6	180	40	25	BX0520	LH040	WD22N2.00..	0.46	340.00
TIWDR2532-2T07	2	25	21.5	7	200	50	32	BX0520	LH040	WD22N2.00..	0.80	360.00
TIWDL2532-2T07	2	25	21.5	7	200	50	32	BX0520	LH040	WD22N2.00..	0.80	360.00
TIWDR2025-3T06	3	20	15	6	180	40	25	BX0520	LH040	WD22N3.00..	0.46	340.00
TIWDL2025-3T06	3	20	15	6	180	40	25	BX0520	LH040	WD22N3.00..	0.46	340.00
TIWDR2532-3T07	3	25	21.5	7	200	50	32	BX0520	LH040	WD22N3.00..	0.80	360.00
TIWDL2532-3T07	3	25	21.5	7	200	50	32	BX0520	LH040	WD22N3.00..	0.80	360.00
TIWDR3240-3T11	3	32	27	11	250	60	40	BX0620	LH050	WD22N3.00..	1.62	420.00
TIWDL3240-3T11	3	32	27	11	250	60	40	BX0620	LH050	WD22N3.00..	1.62	420.00
TIWDR2532-4T09	4	25	21.5	9	200	50	32	BX0520	LH040	WD25N4.00..	0.80	360.00
ATIWDL2532-4T09	4	25	21.5	9	200	50	32	BX0520	LH040	WD25N4.00..	0.80	360.00
ATIWDR3240-4T11	4	32	27	11	250	60	40	BX0620	LH050	WD25N4.00..	1.62	420.00
ATIWDL3240-4T11	4	32	27	11	250	60	40	BX0620	LH050	WD25N4.00..	1.62	420.00
ATIWDR4050-4T11	4	40	38	11	300	80	50	BX0620	LH050	WD25N4.00..	2.93	520.00
ATIWDL4050-4T11	4	40	38	11	300	80	50	BX0620	LH050	WD25N4.00..	2.93	520.00

WD端面槽刀

WDTool holder >> for face grooving
WDFR/L..

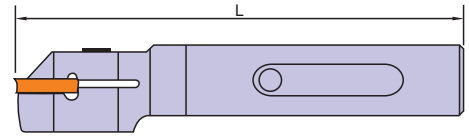
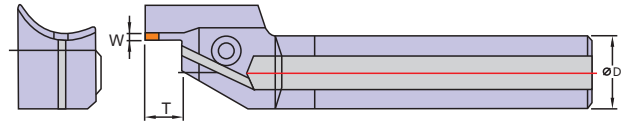
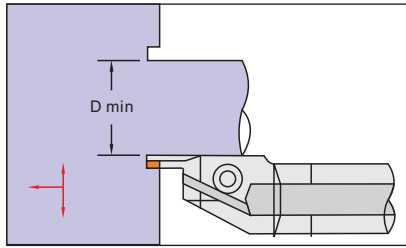

中心出水
Coolant

型号 Type	W	D	T	L1	Dmin	螺钉 Screw	扳手 Wrench	刀片 Inserts	重量 (kg)	单价 (RMB)
A25M-WDFR2934-2T06	2	25	6	150	29	BX0620	LH050	WD22N2.00..	0.50	1350.00
A25M-WDFR3444-2T06	2	25	6	150	34	BX0620	LH050	WD22N2.00..	0.50	1350.00
A25M-WDFR4454-2T06	2	25	6	150	44	BX0620	LH050	WD22N2.00..	0.50	1350.00
A25M-WDFR5470-2T12	2	25	12	150	54	BX0620	LH050	WD22N2.00..	0.50	1350.00
A32M-WDFR70100-2T12	2	32	12	150	70	BX0620	LH050	WD22N2.00..	0.70	1440.00
A32M-WDFR100150-2T12	2	32	12	150	100	BX0620	LH050	WD22N2.00..	0.70	1440.00
A32M-WDFR150250-2T12	2	32	12	150	150	BX0620	LH050	WD22N2.00..	0.70	1440.00
A32M-WDFR250800-2T12	2	32	12	150	250	BX0620	LH050	WD22N2.00..	0.70	1440.00
A25M-WDFR2934-3T12	3	25	12	150	29	BX0620	LH050	WD22N3.00..	0.50	1350.00
A25M-WDFR3444-3T12	3	25	12	150	34	BX0620	LH050	WD22N3.00..	0.50	1350.00
A25M-WDFR4454-3T12	3	25	12	150	44	BX0520	LH050	WD22N3.00..	0.50	1350.00
A25M-WDFR5470-3T20	3	25	20	150	54	BX0520	LH050	WD22N3.00..	0.50	1350.00
A32M-WDFR70100-3T20	3	32	20	150	70	BX0620	LH050	WD22N3.00..	0.70	1440.00
A32M-WDFR100150-3T20	3	32	20	150	100	BX0620	LH050	WD22N3.00..	0.70	1440.00
A32M-WDFR150250-3T20	3	32	20	150	150	BX0620	LH050	WD22N3.00..	0.70	1440.00
A32M-WDFR250800-3T20	3	32	20	150	250	BX0620	LH050	WD22N3.00..	0.70	1440.00
A25M-WDFR2934-4T12	4	25	12	150	29	BX0620	LH050	WD25N4.00..	0.50	1350.00
A25M-WDFR3444-4T12	4	25	12	150	34	BX0620	LH050	WD25N4.00..	0.50	1350.00
A25M-WDFR4454-4T12	4	25	12	150	44	BX0520	LH050	WD25N4.00..	0.50	1350.00
A25M-WDFR5470-4T20	4	25	20	150	54	BX0520	LH050	WD25N4.00..	0.50	1350.00
A32M-WDFR70100-4T20	4	32	20	150	70	BX0620	LH050	WD25N4.00..	0.70	1440.00
A32M-WDFR100150-4T20	4	32	20	150	100	BX0620	LH050	WD25N4.00..	0.70	1440.00
A32M-WDFR150250-4T20	4	32	20	150	150	BX0620	LH050	WD25N4.00..	0.70	1440.00
A32M-WDFR250800-4T20	4	32	20	150	250	BX0620	LH050	WD25N4.00..	0.70	1440.00

WD刀片

Indexable inserts >>

WD

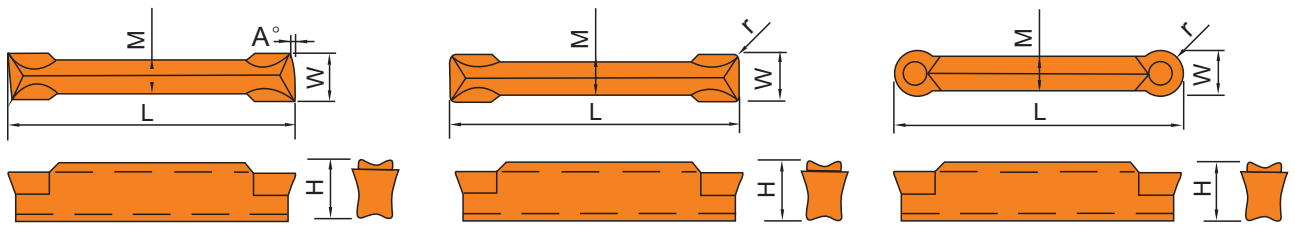

型号 Type	W	L	R	H	A	材质 Grade	单价 (RMB)
						KP2130	
WD22R2.00S-06F	2.0	22	-	4.0	6	●	96.00
WD22L2.00S-06F	2.0	22	-	4.0	6	●	96.00
WD22R3.00S-06F	3.0	22	-	4.0	6	●	98.00
WD22L3.00S-06F	3.0	22	-	4.0	6	●	98.00
WD22N2.00S-0.2F	2.0	22	0.2	4.0	-	●	86.00
WD22N2.00S-0.2M	2.0	22	0.2	4.0	-	●	86.00
WD22N2.00S-0.2T	2.0	22	0.2	4.0	-	●	86.00
WD22N3.00S-0.3F	3.0	22	0.3	4.0	-	●	92.00
WD22N3.00S-0.3M	3.0	22	0.3	4.0	-	●	92.00
WD22N3.00S-0.3T	3.0	22	0.3	4.0	-	●	92.00
WD25N4.00S-0.4F	4.0	25	0.4	4.0	-	●	105.00
WD25N4.00S-0.4M	4.0	25	0.4	4.0	-	●	105.00
WD25N4.00S-0.4T	4.0	25	0.4	4.0	-	●	105.00
WD25N5.00S-0.4F	5.0	25	0.4	4.0	-	●	112.00
WD25N5.00S-0.4M	5.0	25	0.4	4.0	-	●	112.00
WD25N5.00S-0.4T	5.0	25	0.4	4.0	-	●	112.00
WD22N3.00S-1.5R	3.0	22	1.5	4.0	-	●	110.00
WD25N4.00S-2.0R	4.0	25	2.0	4.0	-	●	122.00



P	●	Vc:50-170 m/min
M	●	Vc:50-180 m/min
K	○	Vc:90-160 m/min
N	○	Vc:60-500 m/min
S	○	Vc:10-120 m/min

KOVES[®]

科维丝工具

东莞市科维丝精密工具有限公司

地址：广东省东莞市长安乌沙兴二路33号厂房

KOVES INDUSTRY CO.,LTD

DONGGUAN KOVES PRECISION TOOLS CO.,LTD

No.33 Xing'er Road,Wusha District,Chang'an Town,
Dongguan City,China

Tel:86-0769-81504816

Fax:86-0769-81504815

Http://www.kovestool.cn

E-mail:koves@kovestool.com



DOWNLOAD
扫描下载PDF样本